

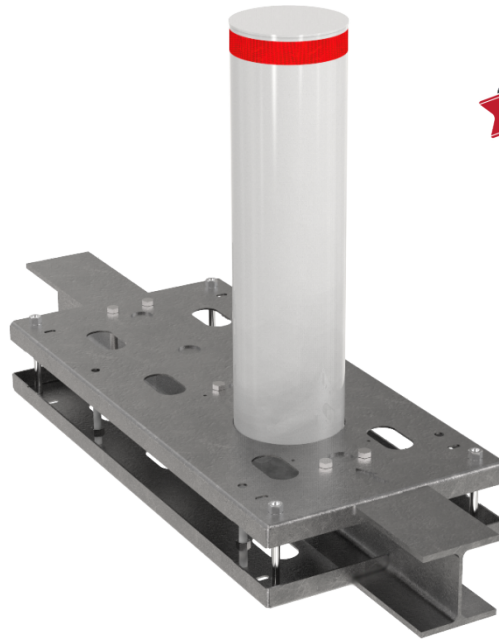

# HBD FIXED BOLLARD SHALLOW MOUNT TECHNICAL SPECIFICATIONS



**PAS 68:2013**  
**IWA 14-1:2013**  
**ASTM F2656-18**

**Bollard Type** : Anti-terror/high security, shallow mount type (bollard underground anchorage height of 210mm only).

**Impact Resistance** : Crash tested and certified according to;

IWA 14-1:2013 Fixed Bollard V/7200[N3C]/64  
PAS68:2013 Fixed Bollard V/7500[N3]/64  
ASTM 2656-18 C740/7200

standards (HBD 275 S 95/8 SRF model).

## **Underground Structure**

### **: Bollard Anchorage**

High resistant bollard anchorage with 2 anchorage plates having gaps for easy and overall penetration of the concrete, strengthened with 200mm thick "HEB" beams on impact direction and having 4 stud bolts/nut for easy levelling. Providing shallow mounting with bollard underground anchorage height of 210mm only.

Underground element connections are extra strengthened by fastening wedge type, 10.9 grade bolted and welded together at the same time.

Bollard post is hot-dip galvanized, strengthened and designed so that no vehicle crashing effect can be displace it after installed into the ground.

## **Above Ground Structure**

### **: Bollard Cylinder (impact blocking unit)**

950mm high from the ground, Ø270 mm hot-dip galvanized steel in RAL9006 color as standard (other RAL colors optionally available).

Furnished with red, white or yellow reflecting strips compliant to "E" standard.



# HBD FIXED BOLLARD SHALLOW MOUNT TECHNICAL SPECIFICATIONS

## Optional Features and Accessories

: Demountable bollard top plate with 360° visible red flashing LED indicators, stainless steel bollard post sleeve, different color options, different product dimensions.

## Installation

: With 4 bolts for easy leveling and gaps for easy and overall penetration of the concrete easy installation using C30 grade concrete and steel rebar reinforcement.

Ground leveling and preparation works shall be done before concrete pouring. Allowable bearing value of the ground shall be minimum 1/2 kg/cm<sup>2</sup>.

